

MODEL	FXC 2H 4020 B
WEIGHT	NA
RATED VOLTAGE	400 V
PHASES	3 + N
NOMINAL FREQUENCY	50/60 Hz
NOMINAL CURRENT	52 A
NOMINAL POWER	33,2 kW

Thermal switcher required: 0.3 A in "D" curve

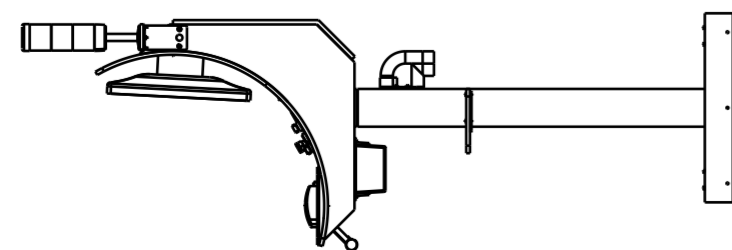
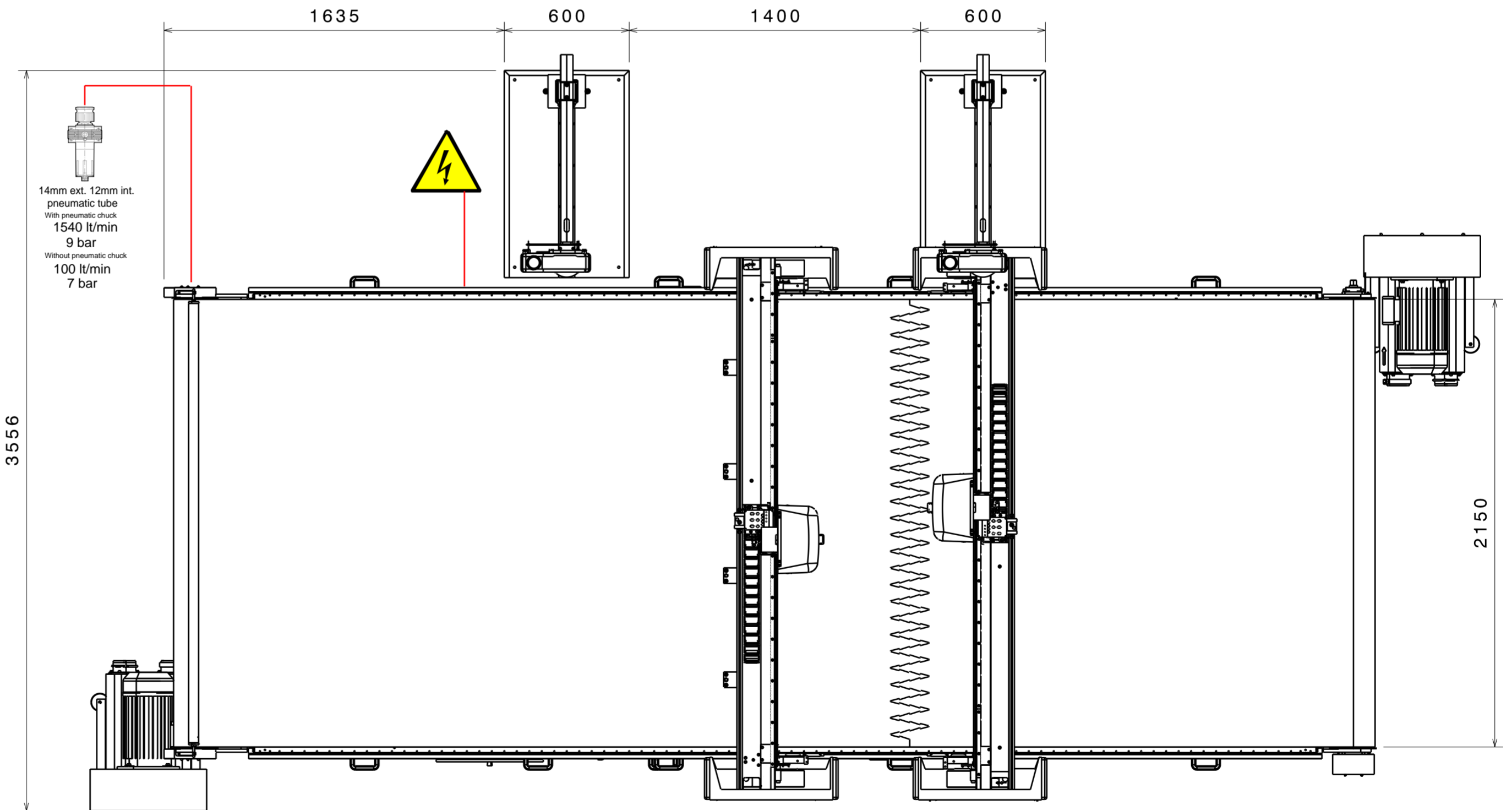
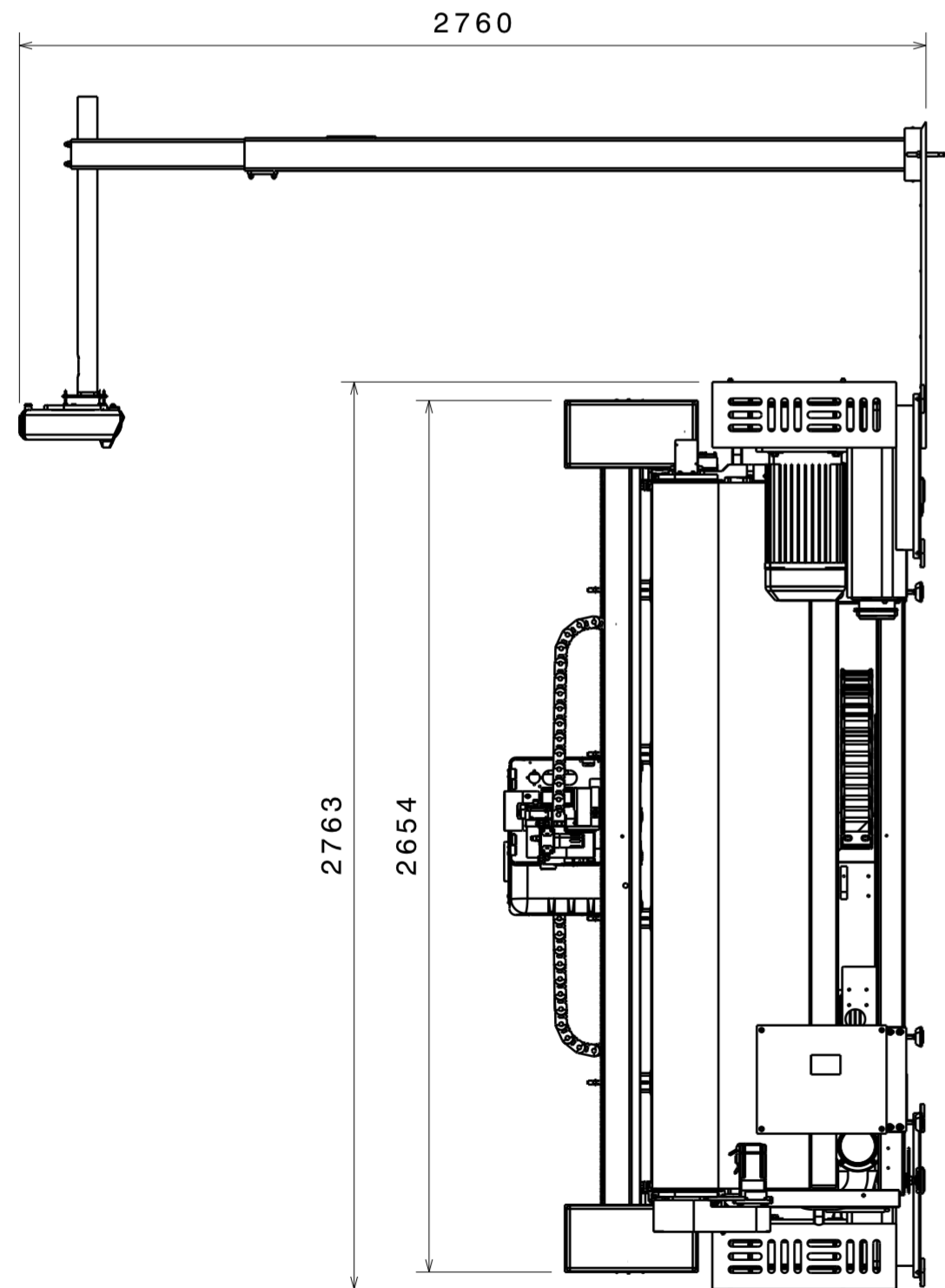
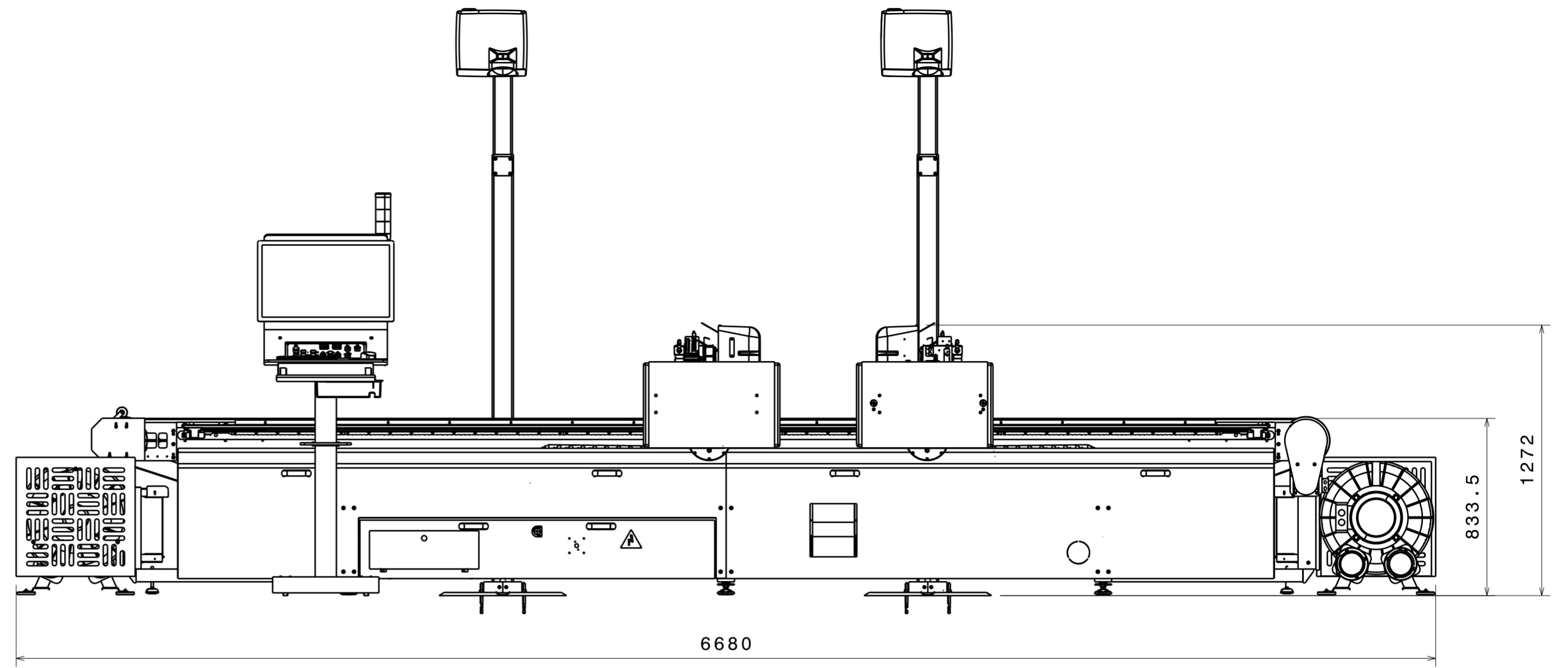

It is the user's responsibility to ensure the required connection requirements