

12mm ext. 10mm int.
pneumatic tube
With pneumatic chuck
770 lt/min
9 bar
Without pneumatic chuck
100 lt/min
7 bar

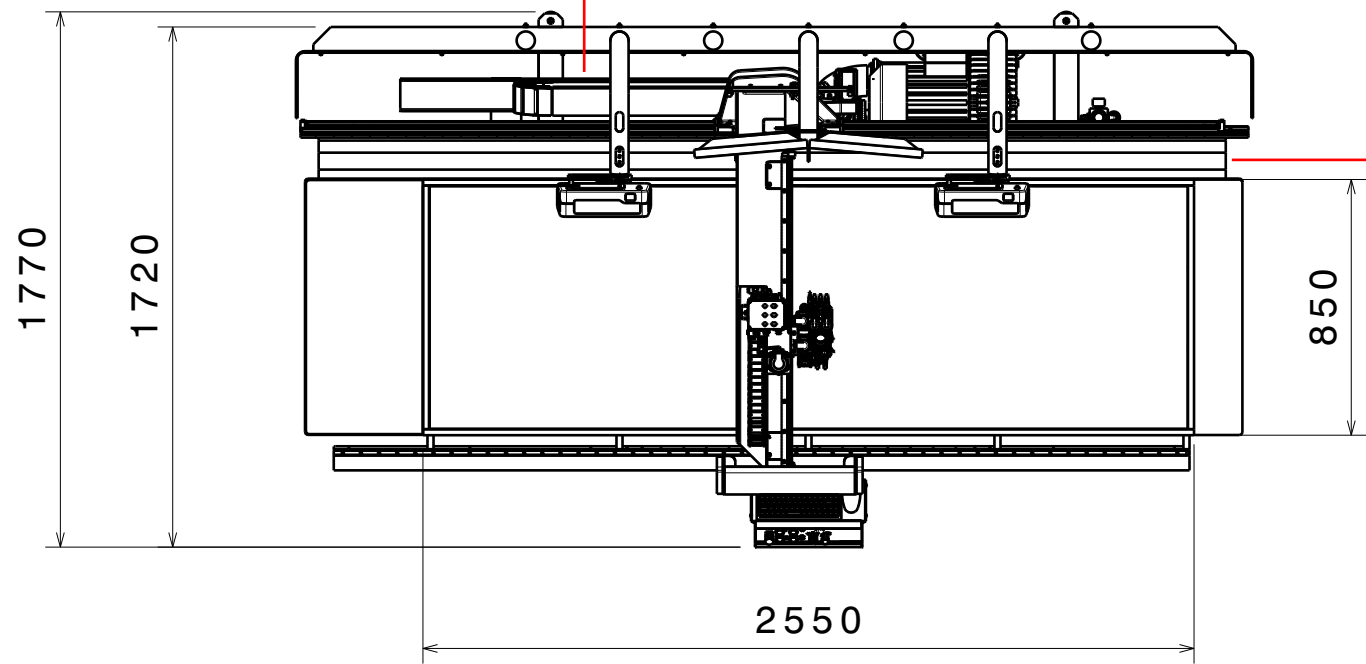
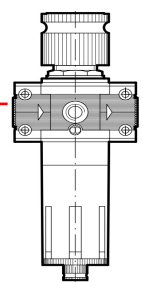

MODEL	FC 888M25	
WEIGHT	1060 Kg	
RATED VOLTAGE	400 V	220 V
PHASES	3 + N	3
NOMINAL FREQUENCY	50 Hz	60 Hz
NOMINAL CURRENT	13 A	25 A
NOMINAL POWER	6,5 kW	7,5 kW

Thermal switcher required: 0.3 A in "D" curve

It is the user's responsibility to ensure the required connection requirements

