

Installation site

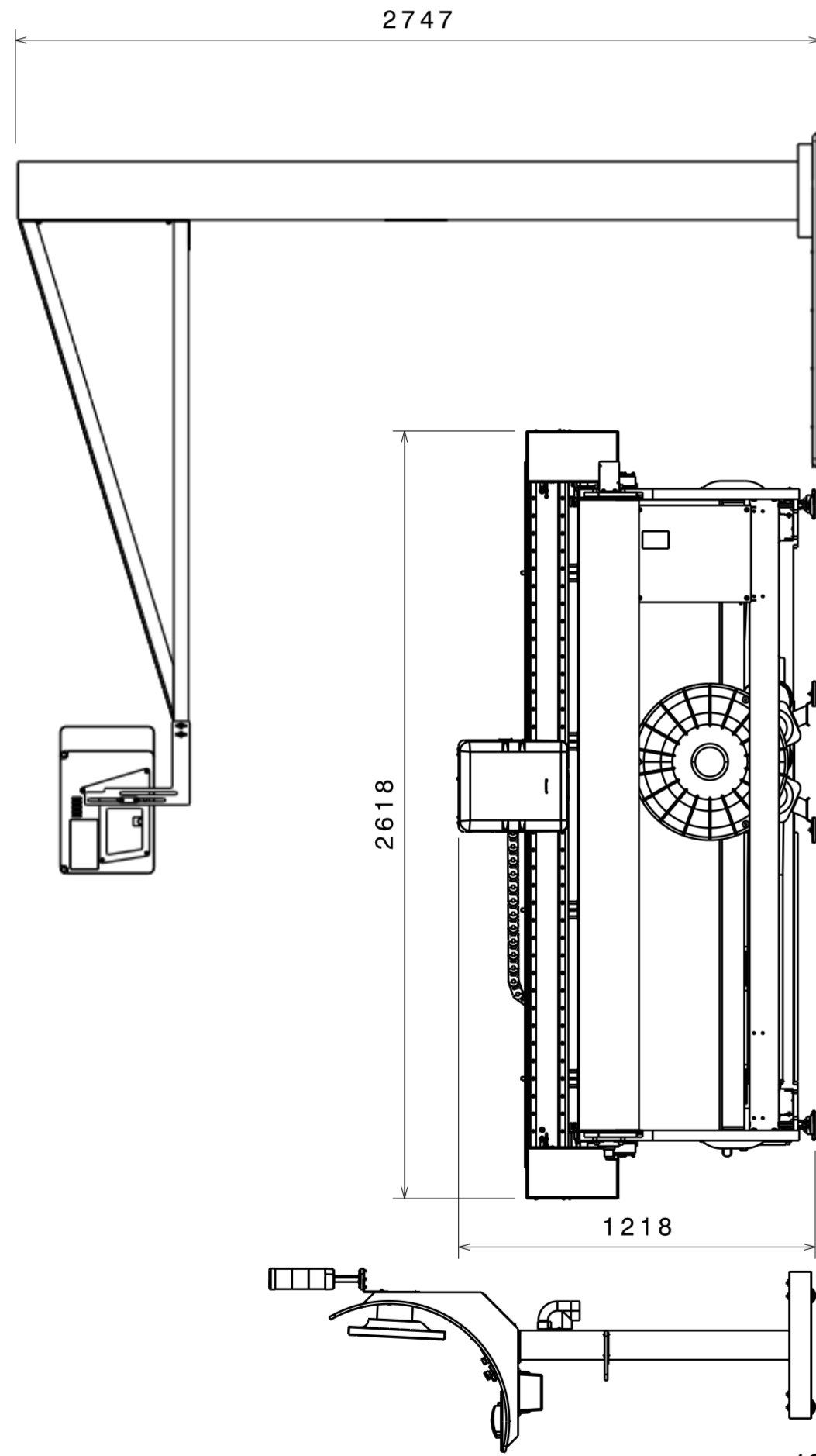

12mm ext. 10mm int.  
pneumatic tube  
With pneumatic chuck  
**770 lt/min**  
9 bar  
Without pneumatic chuck  
100 lt/min  
7 bar

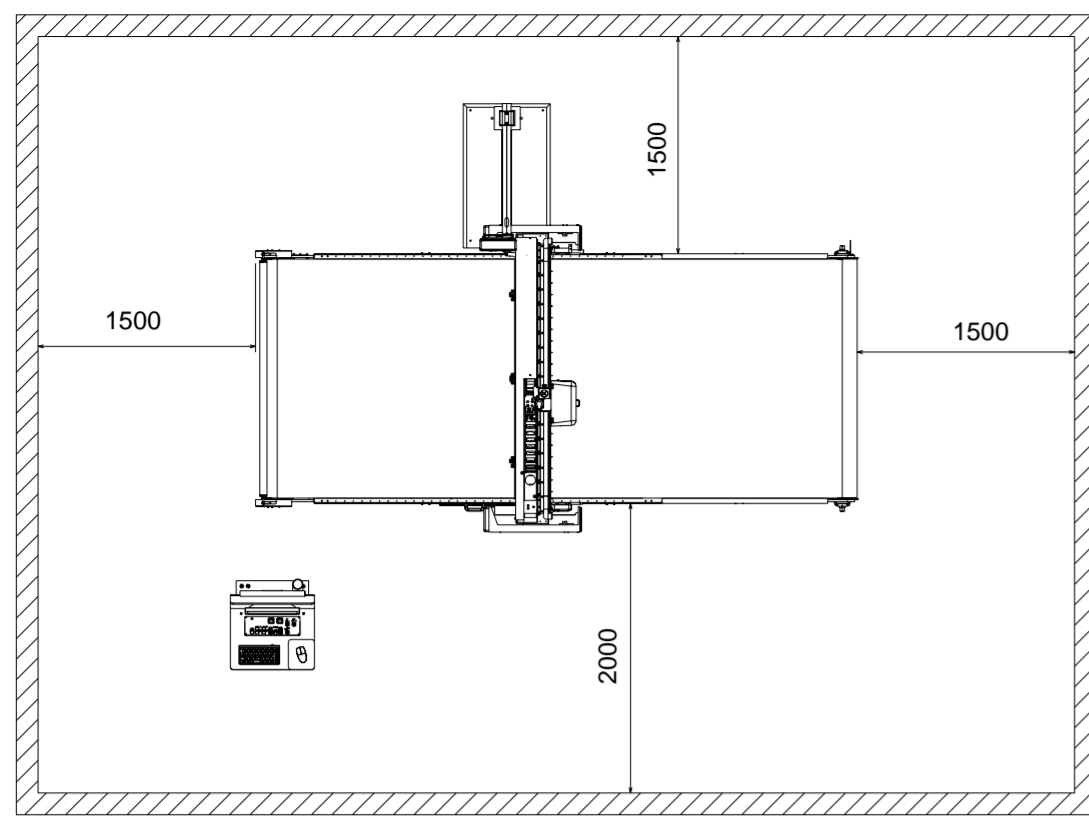
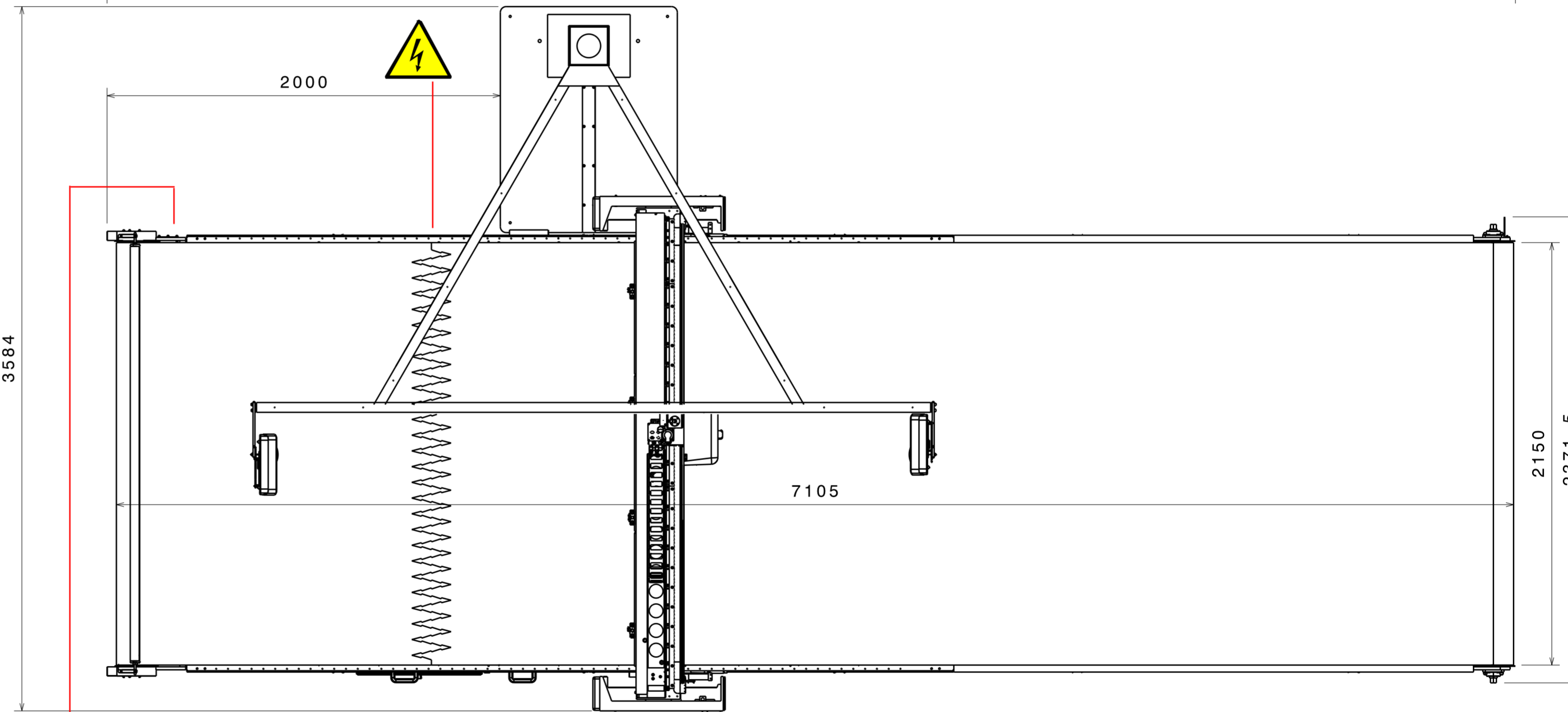
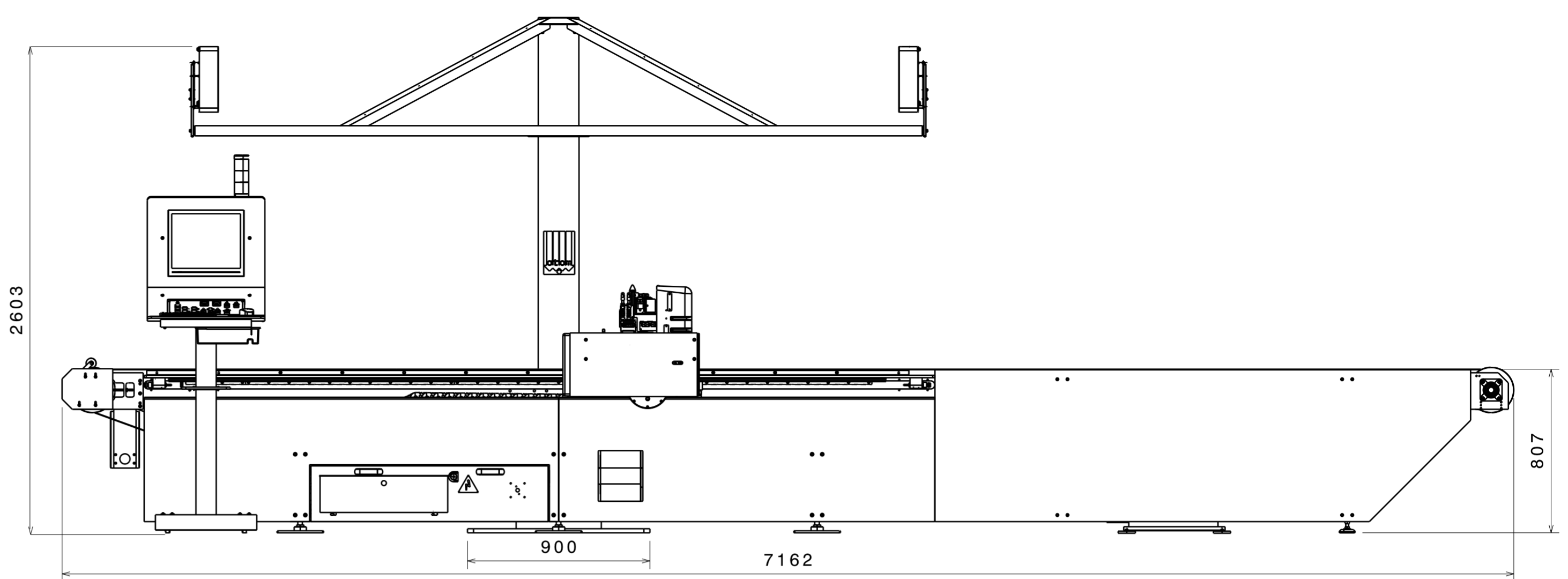
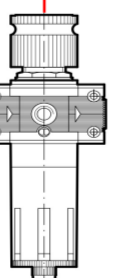

MODEL	FXC 3020/B2 1P		FXC 3020/B2 UP 1P		FXC 3020/B2 2P		FXC 3020/B2 UP 2P	
WEIGHT	2450 Kg		2770 Kg		2600 Kg		2920 Kg	
RATED VOLTAGE	380...415 V	220 V	380...415 V	220 V	380...415 V	220 V	380...415 V	220 V
PHASES	3 + N	3	3 + N	3	3 + N	3	3 + N	3
NOMINAL FREQUENCY	50/60 Hz	50/60 Hz	50/60 Hz	50/60 Hz	50/60 Hz	50/60 Hz	50/60 Hz	50/60 Hz
NOMINAL CURRENT	27 A	47 A	27 A	47 A	49,5 A	87 A	49,5 A	87 A
NOMINAL POWER	17,1 kW	17,1 kW	17,1 kW	17,1 kW	31,7 kW	31,5 kW	31,7 kW	31,5 kW

Thermal switcher required: 0.3 A in "D" curve

It is the user's responsibility to ensure the required connection requirements

