

MODEL	FXC 3015/B 1P		FXC 3015/B UP 1P		FXC 3015/B 2P		FXC 3015/B UP 2P	
WEIGHT	1850 Kg		1990 Kg		2000 Kg		2140 Kg	
RATED VOLTAGE	380...415 V	220 V	380...415 V	220 V	380...415 V	220 V	380...415 V	220 V
PHASES	3 + N	3	3 + N	3	3 + N	3	3 + N	3
NOMINAL FREQUENCY	50/60 Hz	50/60 Hz	50/60 Hz	50/60 Hz	50/60 Hz	50/60 Hz	50/60 Hz	50/60 Hz
NOMINAL CURRENT	27 A	47 A	27 A	47 A	49,5 A	87 A	49,5 A	87 A
NOMINAL POWER	17,1 kW	17,1 kW	17,1 kW	17,1 kW	31,7 kW	31,5 kW	31,7 kW	31,5 kW

Thermal switcher required: 0.3 A in "D" curve

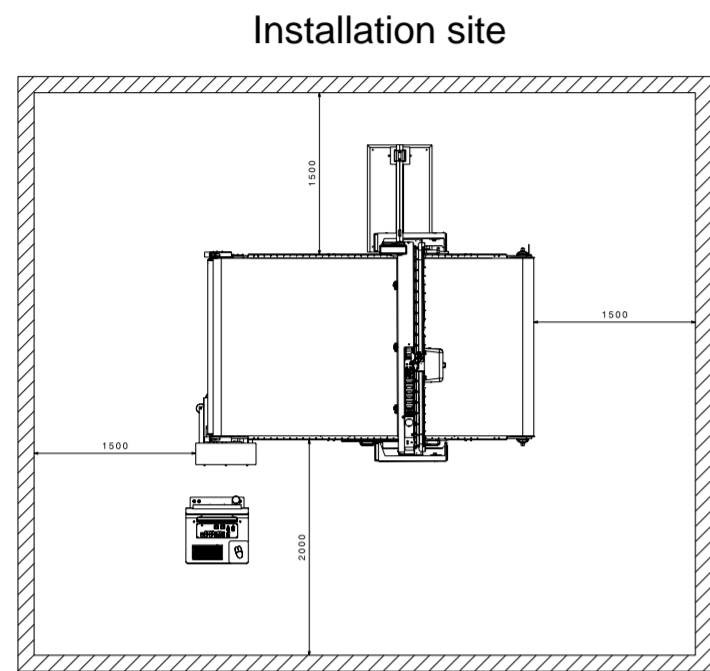

14mm ext. 12mm int.
pneumatic tube
With pneumatic chuck
770 lt/min
9 bar
Without pneumatic chuck
100 lt/min
7 bar

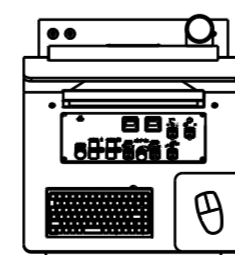
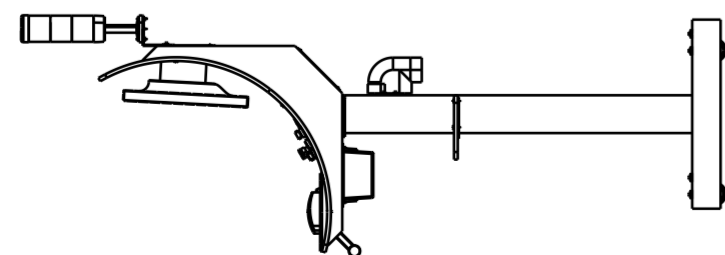
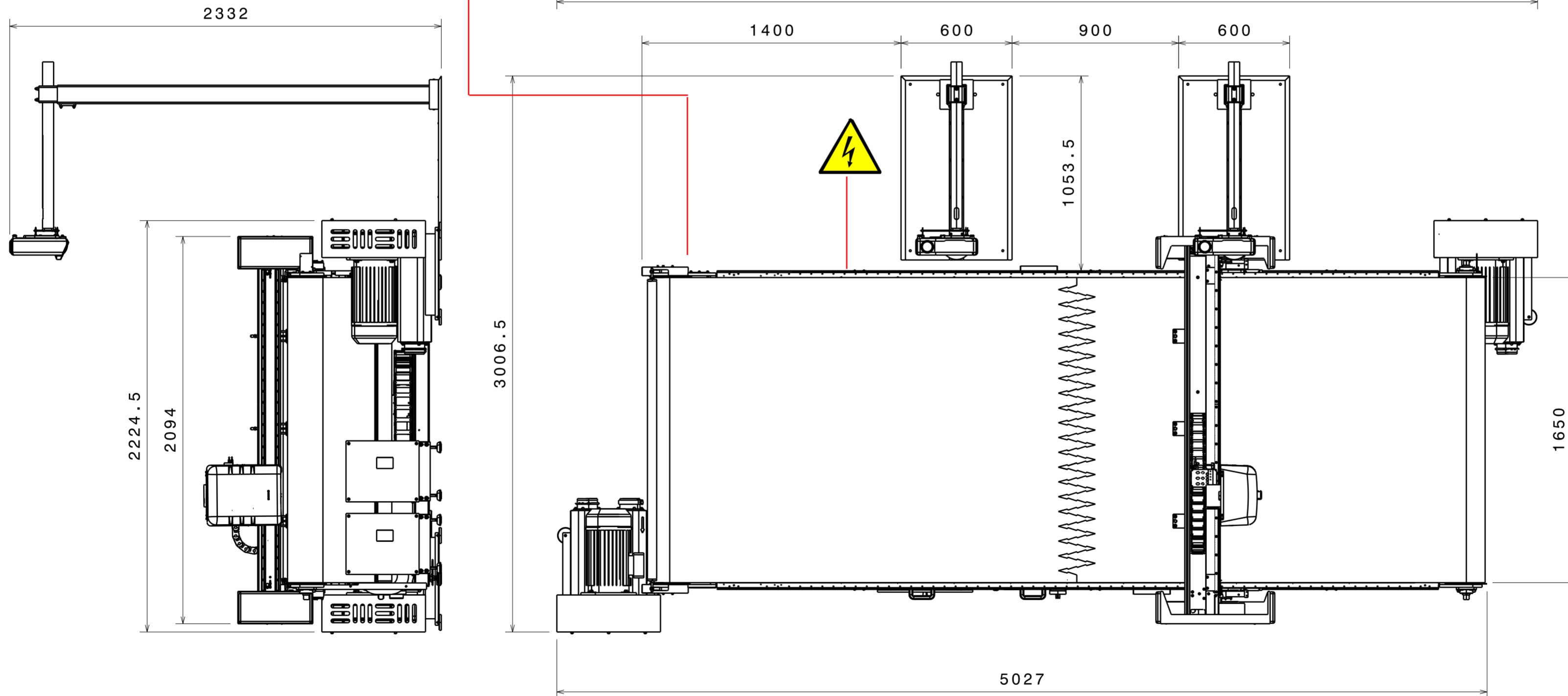
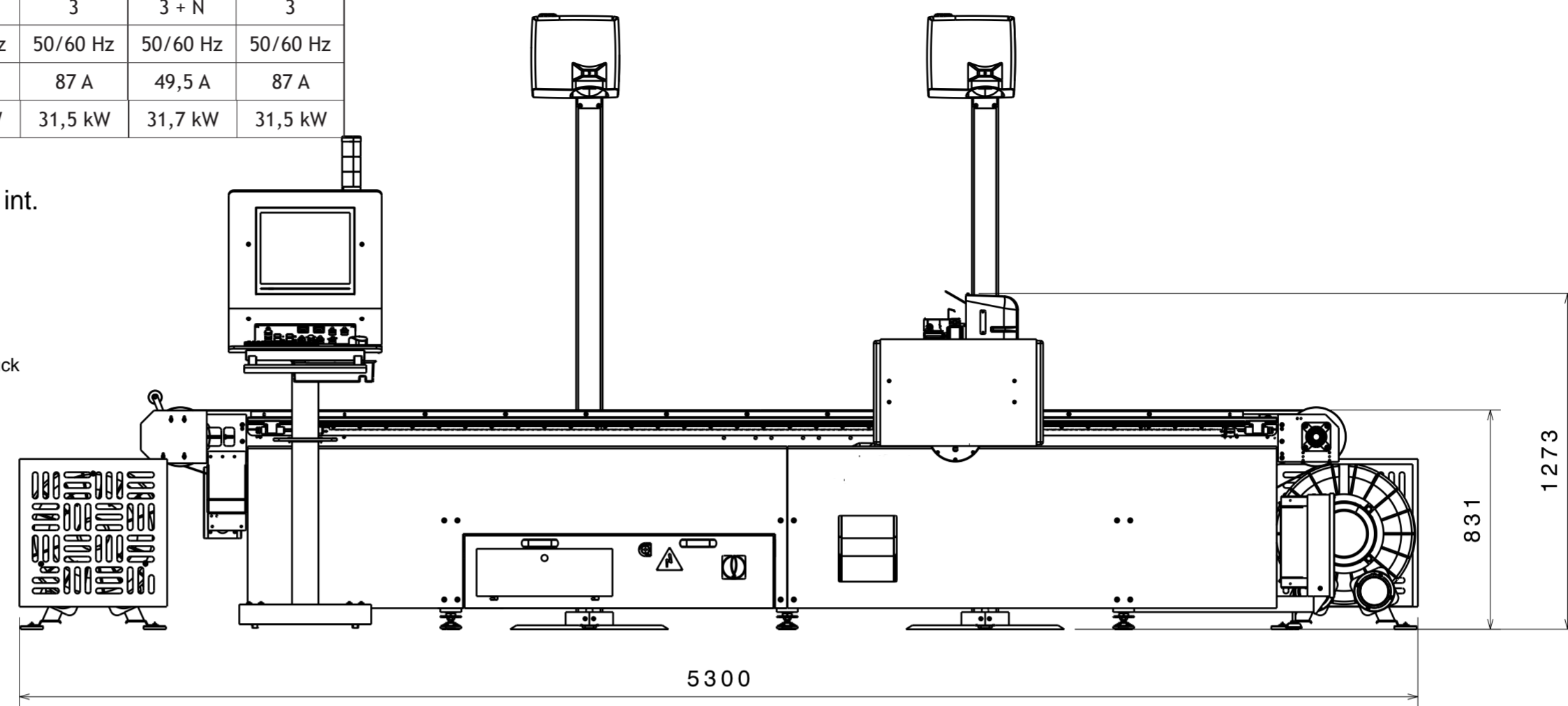
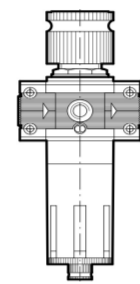

It is the user's responsibility to ensure the required connection requirements