

MAIN SWITCH LOCATED HERE
CABLE COMES IN THROUGH THE BACK OF
THE MACHINE AND HAS TO BE FLEXIBLE
BECAUSE THIS IS A DRAWER THAT PULLS
OUT TO EXPOSE ALL OF THE ELECTRICAL
COMPONENTS

THIS STEEL PLATE IS USUALLY BOLTED TO THE SKID
AND IS USED FOR PROJECTION ALIGNMENT. PLEASE
MAKE SURE THIS DOESN'T GET DISPOSED OF.

AIR HOOKUP

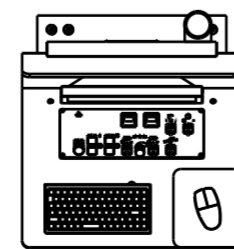
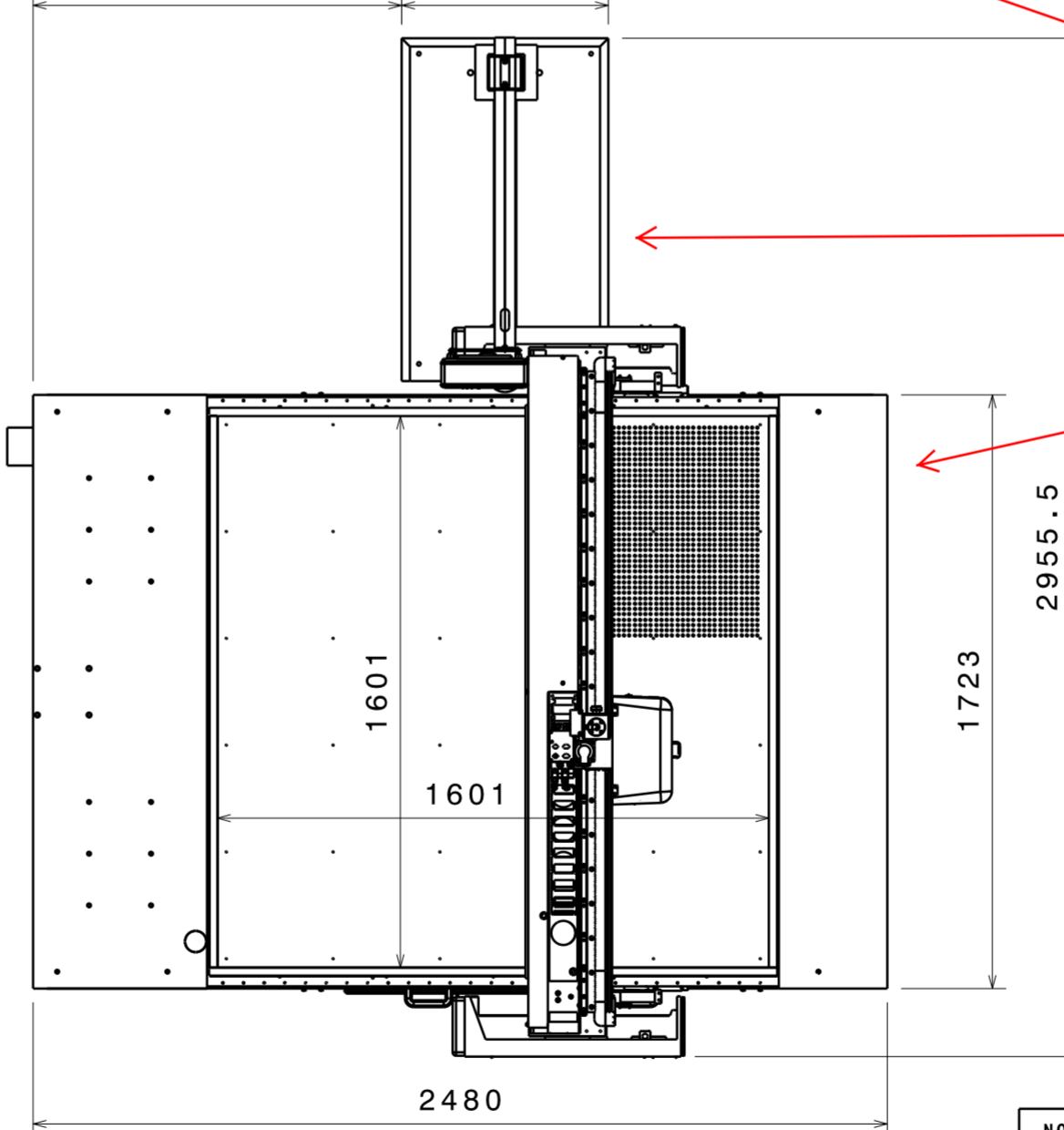

NON MISURARE IN SCALA NEL DUBBIO CHIEDERE		D	-	-	-
Tolleranze generali di lavorazione		C	-	-	-
Quote lin. (Ø comp.): sino a 18 ± 0.15		B	-	-	-
" " " > 18 a 80 ± 0.25		A	-	-	-
" " " > 80 ± 0.4		N.	Data	Oggetto modifica	Firma
Angoli < ± 0'30"					
Arrottondare o smussare gli spigoli non quotati con R=0.3 o smusso 0.3 a 45°					
Scale: 1:20	Data: 16/11/10	Denom. Layout FlexCut 1515/S		Peso grezzo= 0,00 kg	
				Peso finito= 0,00	
Disegn. Galante		Mod.	-	Stato	
Visto		Quant.	-	Mater.	
Area m²		Finit.	-	Schema	
Tratt.term.		Durezza	-	Dis. N° FC1515/S	