

12mm ext. 10mm int.  
pneumatic tube  
With pneumatic chuck  
**1540 lt/min**  
9 bar  
Without pneumatic chuck  
**100 lt/min**  
7 bar

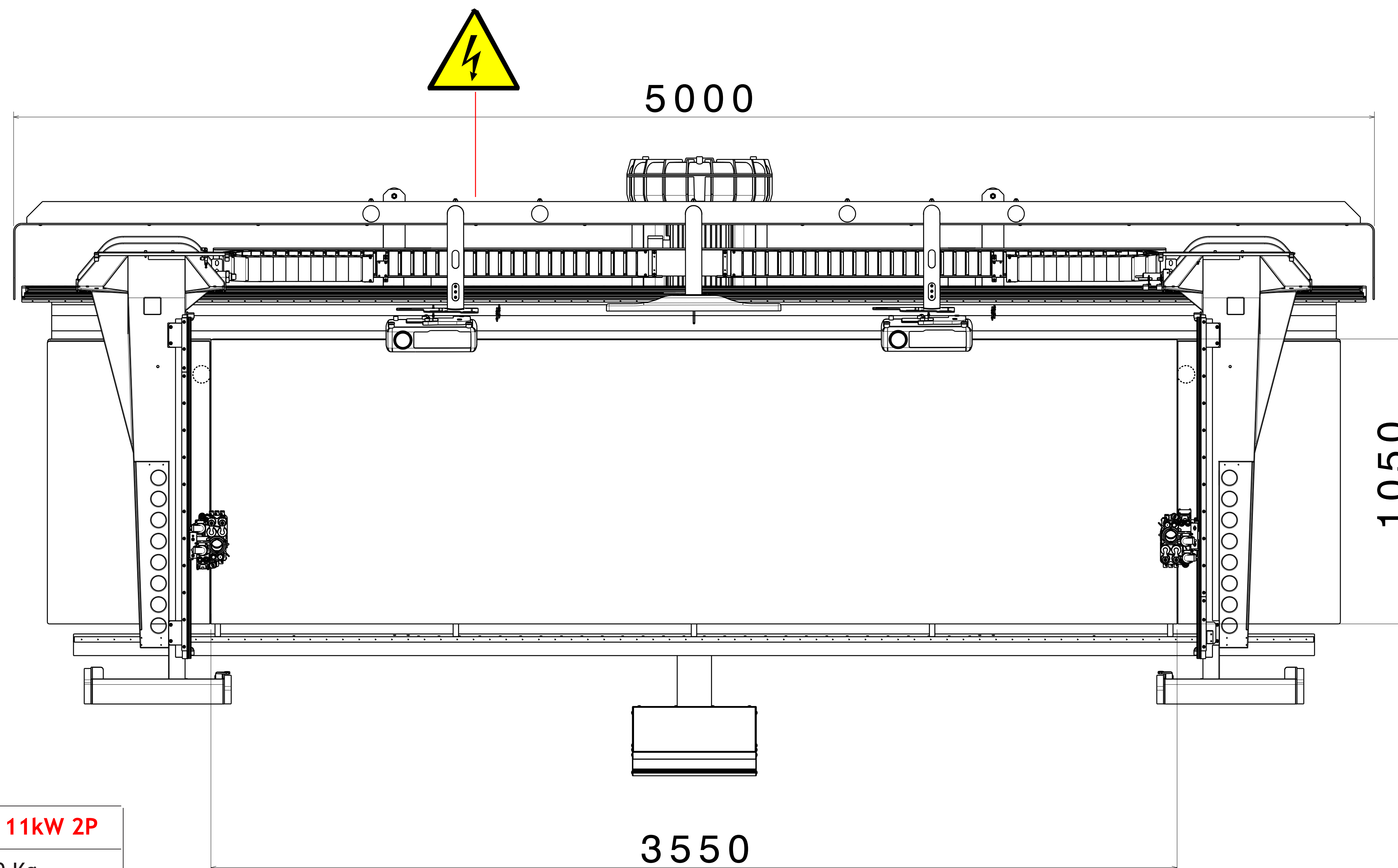

MODEL	FC 888L35 11kW 1P		FC 888L30 11kW 2P	
WEIGHT	1526 Kg		1660 Kg	
RATED VOLTAGE	400 V	220 V	400 V	220 V
PHASES	3 + N	3	3 + N	3
NOMINAL FREQUENCY	50 Hz	60 Hz	50 Hz	60 Hz
NOMINAL CURRENT	28,5 A	49 A	51 A	88 A
NOMINAL POWER	14,1 kW	14,1 kW	27,1 kW	27,1 kW

Thermal switcher required: 0.3 A in "D" curve

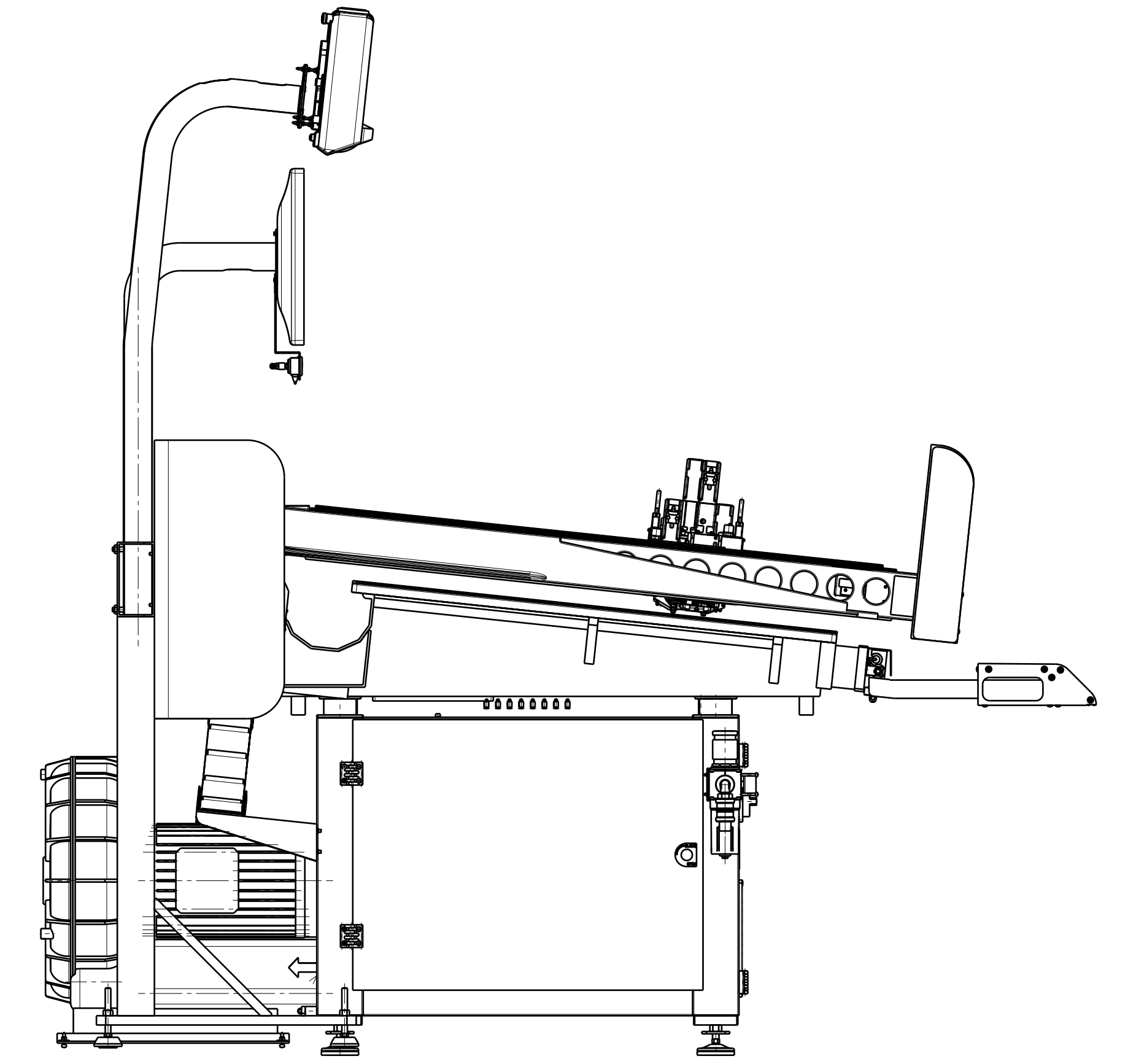
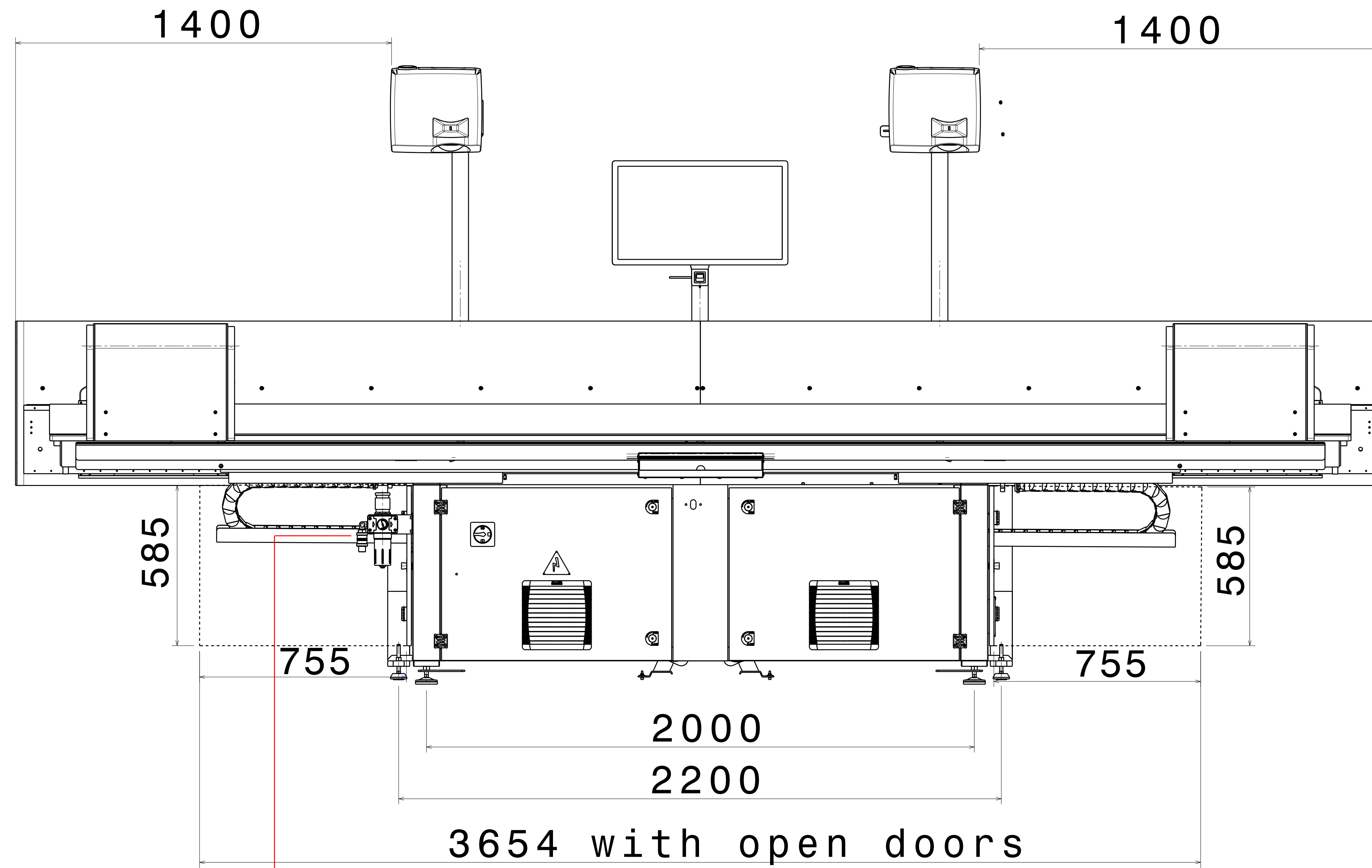

It is the user's responsibility to ensure the required connection requirements